



Technical Data Sheet Type 91



2/2-Way solenoid valve
Valve normally closed (NC).
When energized the solenoid first opens the pilot hole and then lifts directly or supported by a pressure difference the piston from the valve seat. The valve is closed by spring power.

■ Solenoid valve for cryogenic fluids

Type 91

TECHNICAL SPECIFICATIONS VALVE FEATURES

Type of control:	Force pilot operated, no pressure difference required
Design:	Piston design
Connection:	Female thread acc. to DIN ISO 228 Welding ends, NPT on request Further connections like flanges acc. to EN 1092 are available on request
Installation:	Actuator only in upright position
Pressure:	0-16 bar and 0-40 bar (see table page 2)
Medium:	Clean, neutral, gaseous and liquid medium
Viscosity:	22 mm ² /s
Temperature range:	Medium: -196 °C up to +60 °C Ambient: -40 °C up to +50 °C In consideration of the restrictions described on page 6
Body material:	PN16: Brass PN16: Stainless steel 1.4581 PN50: Stainless steel 1.4404
Metallic inner parts:	Brass and stainless steel
Sealing:	PTFE
Supply voltage:	AC~ 24V, 110V, 230V; 50-60Hz DC= 12V, 24V, 110V Other supply voltages on request
Voltage tolerance:	-10% / +10%
Power consumption:	.802 = 24 Watt .808 = 24 Watt .322 = 30 Watt .328 = 24 Watt .242 = 46 Watt .248 = 30 Watt .272 = 100 Watt .278 = 47 Watt
Protection class:	IP65 according to DIN EN 60529
Duty factor:	100% ED DIN VDE 0580
Ex-proof:	Ex e mb II T4 Further Ex-proof on request

- For cryogenic media to -196 °C (incl. LNG)
- No pressure difference is required
- High life time
- Simple compact valve design
- Reliable and sturdy sealing elements
- Long-term availability of spare parts
- High-quality materials
- NO (normally open) available
- AS (Welding ends)
- FL (Flange design)

FUNCTION

NC - non energized closed

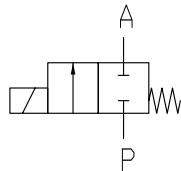

NO - non energized open

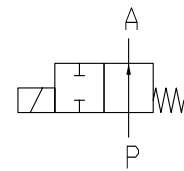

CERTIFICATES



ORDERING SYSTEM

A	91	23	/	08	04	/	.	80	2	-	A	S
Type	Connection	Body	Actuator	Valve options								
A PN16	21 G ¹ / ₄	08 Stainless steel	2 Standard IP65									
B PN50	22 G ³ / ₈	1.4581 / 1.4404	8 explosion proof acc. to Directive 94/9/EG (ATEX)									
	23 G ¹ / ₂	10 Brass										
	24 G ³ / ₄	Seal										
	25 G1	04 PTFE										
	26 G ¹ / ₄											
	27 G ¹ / ₂											
	28 G2											

TECHNICAL FEATURES

PN16									
G	Seat ø mm	Kv-value m ³ /h	Standard type	Coil					
				.802	.322	.242	.328	.248	.278
1/4	13,5	1,7	A9121/..04/..	0-16	-	-	0-16	-	-
3/8	13,5	3,8	A9122/..04/..	0-16	-	-	0-16	-	-
1/2	13,5	4,4	A9123/..04/..	0-16	-	-	0-16	-	-
3/4	25	11,2	A9124/..04/..	0-16	-	-	0-16	-	-
1	27,5	13,0	A9125/..04/..	0-16	-	-	0-16	-	-
1 1/4	40	28,5	A9126/..04/..	-	0-16	-	-	0-16	-
1 1/2	40	32,0	A9127/..04/..	-	0-16	-	-	0-16	-
2	50	47,0	A9128/..04/..	-	-	0-16	-	-	0-16

PN50									
DN	Seat ø mm	Kv-value m ³ /h	Standard type	Coil					
				.322	.242	.272	.248	.278	
1/4	13,5	1,8	B9121/0804/....-AS	0-40	-	-	0-40	-	-
3/8	13,5	4,0	B9122/0804/....-AS	0-40	-	-	0-40	-	-
1/2-15	13,5	4,5	B9123/0804/....-AS	0-40	-	-	0-40	-	-
3/4-20	25	11,5	B9124/0804/....-AS	0-40	-	-	0-25	0-40	-
1-25	27,5	13,0	B9125/0804/....-AS	0-40	-	-	0-25	0-40	-
1 1/4-32	40	29,0	B9126/0804/....-AS	-	0-25	0-40	0-25	0-40	-
1 1/2-40	40	33,0	B9127/0804/....-AS	-	0-25	0-40	0-25	0-40	-
2-50	50	47,0	B9128/0804/....-AS	-	-	0-40	-	0-40	-

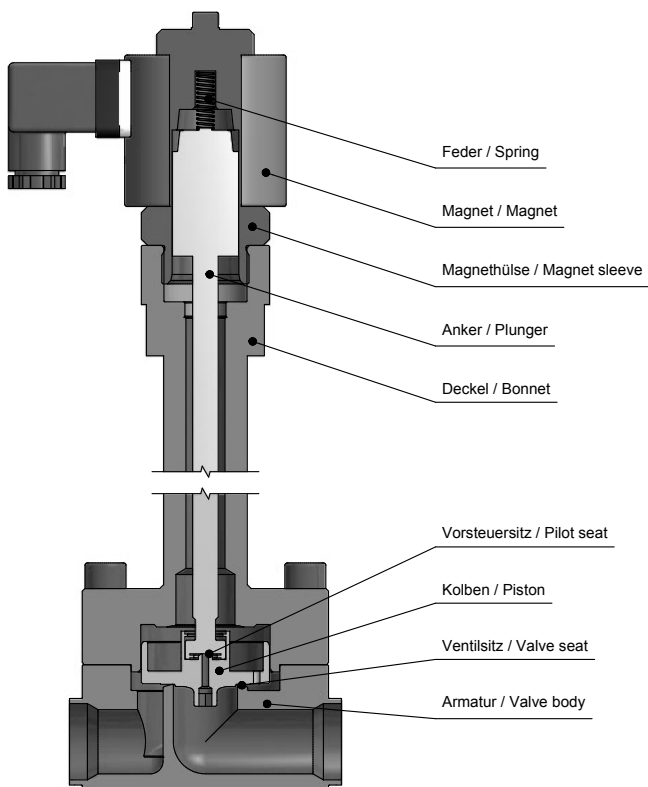

DIMENSIONS

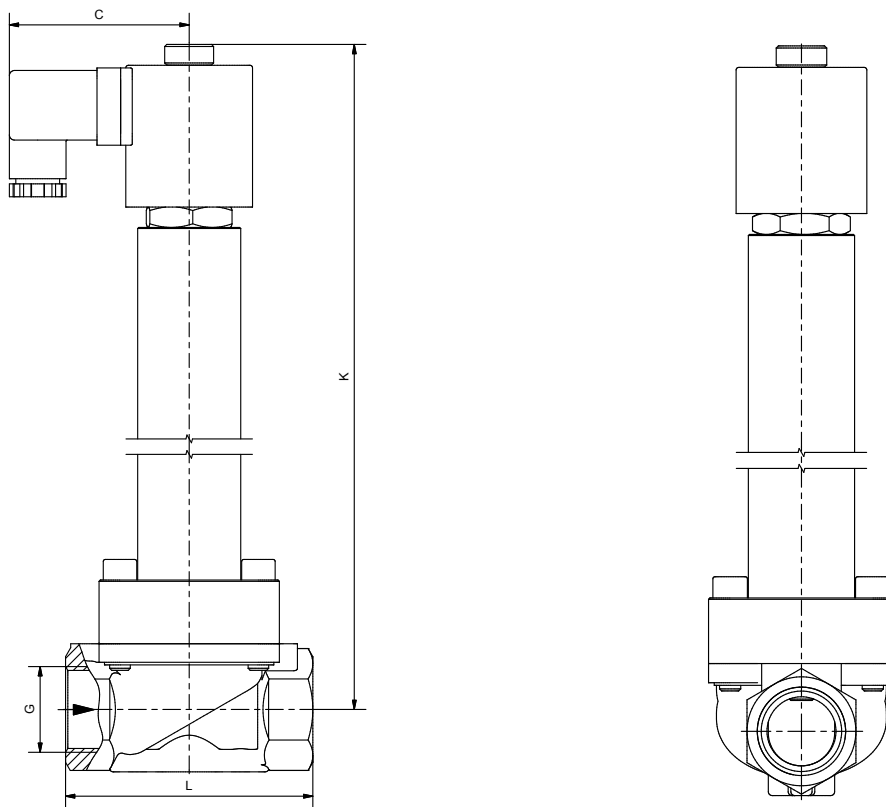

PN16

Coil	.802					.322		.242		
Type	A9121	A9122	A9123	A9124	A9125	A9126	A9127	A9126	A9127	A9128
G	1/4	3/8	1/2	3/4	1	1 1/4	1 1/2	1 1/4	1 1/2	2
C	70	70	70	70	70	77	77	93	93	93
K	365	365	365	400	400	475	475	500	500	510
L	67	67	67	96	96	140	140	140	140	168
kg	2,2	2,2	2,2	4,4	4,4	8,8	8,8	9,7	9,7	10,3

PN16

Coil	.328							.248		.278
Type	A9121	A9122	A9123	A9124	A9125	A9126	A9127	A9126	A9127	A9128
G	1/4	3/8	1/2	3/4	1	1 1/4	1 1/2	1 1/4	1 1/2	2
C	83	83	83	83	83	83	83	93	93	106
K	370	370	370	405	405	475	475	500	500	560
L	67	67	67	96	96	140	140	140	140	168
kg	3,3	3,3	3,3	5,4	5,4	9	9	9,8	9,8	13

DIMENSIONS

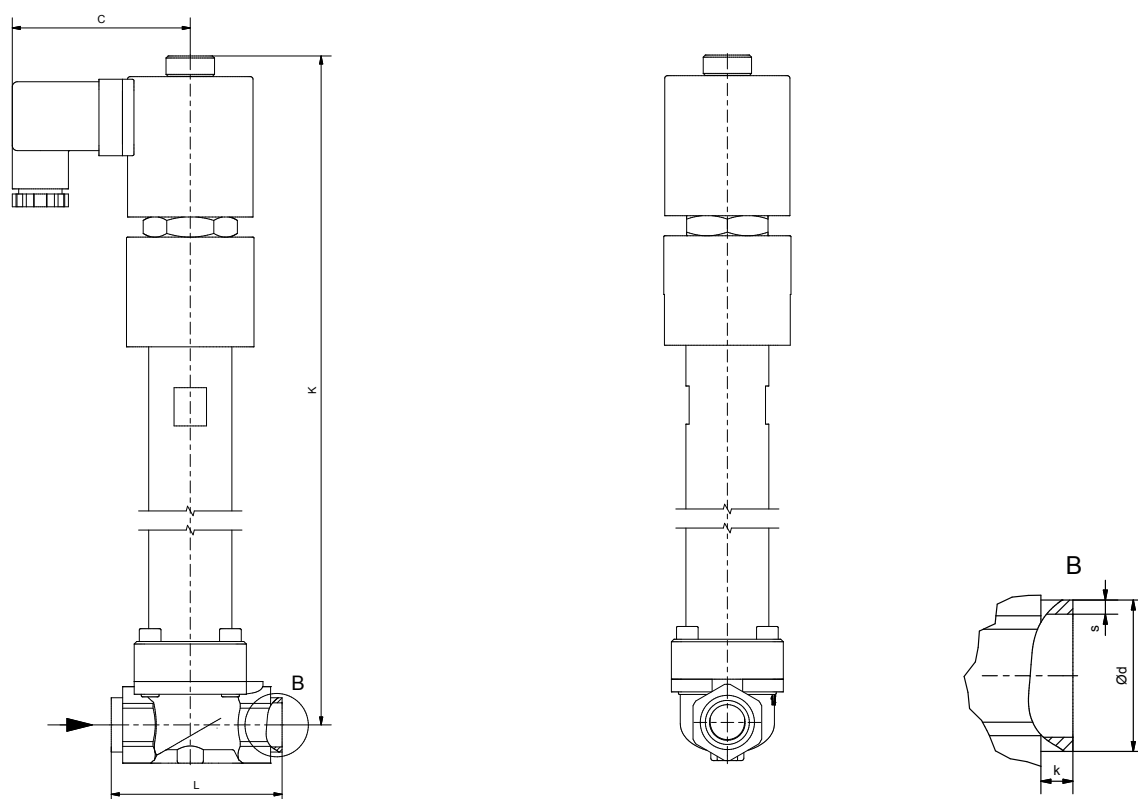

PN16

Coil	.802				.322			.242
Type	A9121	A9122	A9123	A9124	A9125	A9126	A9127	A9128
DN	13,5	13,5	13,5	25	27,5	40	40	50
C	70	70	70	70	77	77	77	93
K	385	385	385	420	425	495	495	530
L	67	67	67	96	96	140	140	168
d	24	24	24	30	36	45	52	65
s	3,5	3,5	3,5	4	4	5	5,5	5,5
k	12	12	12	12	14	17	18	22
kg	2,2	2,2	2,2	4,4	5,3	8,8	8,8	10,3

Coil	.328				.248			.278
Type	A9121	A9122	A9123	A9124	A9125	A9126	A9127	A9128
DN	13,5	13,5	13,5	25	27,5	40	40	50
C	83	83	83	83	83	93	93	106
K	390	390	390	425	425	505	505	560
L	67	67	67	96	96	140	140	168
d	24	24	24	30	36	45	52	65
s	3,5	3,5	3,5	4	4	5	5,5	5,5
k	12	12	12	12	14	17	18	22
kg	3,3	3,3	3,3	5,4	5,4	9,8	9,8	13

DIMENSIONS

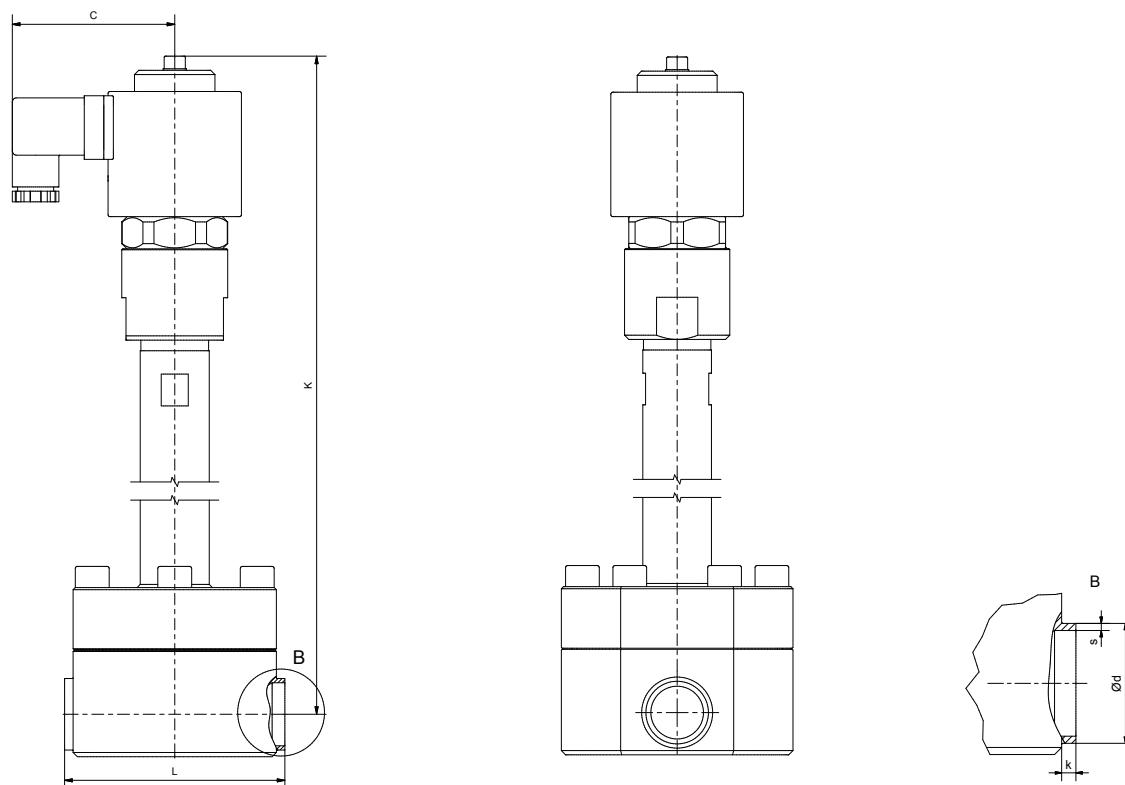

Type 91

PN50

Coil	.322					.242		.272		
Type	B9121	B9122	B9123	B9124	B9125	B9126	B9127	B9126	B9127	B9128
DN	13,5	13,5	13,5	25	27,5	40	40	40	40	50
C	77	77	77	77	77	93	93	107	107	107
K	408	408	408	424	424	505	505	525	525	560
L	80	80	80	104	102	148	147	148	147	178
d	24	24	24	30	36	45	52	45	52	65
s	3,5	3,5	3,5	4	4	5	5,5	5	5,5	5,5
k	2	2	2	4	4	4	3,5	4	3,5	4
kg	3,3	3,3	3,3	5,4	5,4	9,8	9,8	12,3	12,3	13

Coil	.248					.278		
Type	B9121	B9122	B9123	B9124	B9125	B9126	B9127	B9128
DN	13,5	13,5	13,5	25	27,5	40	40	50
C	93	93	93	93	93	106	106	106
K	418	418	418	434	434	535	535	560
L	80	80	80	104	102	148	147	178
d	24	24	24	30	36	45	52	65
s	3,5	3,5	3,5	4	4	5	5,5	5,5
k	2	2	2	4	4	4	3,5	4
kg	4,5	4,5	4,5	6,6	6,6	12,3	12,3	13

INFORMATION

- It is imperative to observe the installation and safety instructions in our operating and service manuals.
- For information on our GSR ordering code, please refer to our catalogs. If you have any questions, we will be glad to assist you.
- Required ordering information: valve type, function NC/NO, pressure range, connection, nominal width, medium, flow rate, medium and ambient temperatures, connection voltage.
- **Detailed production-specific drawings and other technical information will be made available when an order is placed.**

PLEASE NOTE

Each individual application decides which valve type is required, the main factor being the resistance of the materials to the operating medium. The correct selection of materials requires knowledge of the concentration, temperature and degree of contamination of the medium. Other criteria include the operating pressure and max. volumetric flow, since, in addition to high temperatures, high pressures and high flow rates must also be taken into account when selecting the materials.

All materials used for our valves, be it housing, seals or magnets, will be carefully selected in view of the different application areas. Any information given is non-binding and serves for orientation only. No claims under warranty can be derived therefrom.

Heating and power of solenoid coils

The GSR default solenoid valves are designed for continuous operation (100% ED = power-on time) under normal operating conditions. The pulling force of a solenoid coil is basically influenced by three elements:

- The self-heating of the magnetic coil
- The medium temperature
- The ambient temperature

GSR solenoid coils are by default designed for a maximum ambient temperature of +40 °C. This specification applies for the maximum allowable operating pressure specified in the data sheet of the corresponding valve and a medium temperature of +60 °C.

A higher ambient temperature is possible, when lower values are applied for the other influencing parameters. When the max. operation pressure and max. ambient temperature of +50 °C is given the medium temperature is not allowed to be higher than max. +50 °C. In addition to that, deviations from the default design temperature range are possible, e.g. when temperature coils or other constructive measures are used. Please contact the GSR headquarters to discuss the specific application.

More precise specifications and technical data with regard to the operating conditions can be found in the data sheets of the solenoid coils and the solenoid valve regarded. Please observe that the surface temperature of a permanently loaded coil can amount up to +120 °C, solely by the self-heating of the coil. The power consumption of our default solenoid valves was calculated to DIN VDE 05820 for a coil temperature of +20 °C.

- The GSR logo is a registered trademark of GSR Ventiltechnik GmbH & Co. KG.
- Note: All texts and images are the property of GSR Ventiltechnik GmbH & Co. KG and must not be replicated or modified, not even in part, without written approval.
- Original products may differ from the product images shown, due to different materials and the like.
- Subject to error and changes.

State: 12/2015, MK-MG, Version 2.

